

Customised Carbide End Mill - Ordering Form

Note: Kindly fill up your Custom requirement in this form and Fax to 65-62431957 or Email to sales@stamfordtools.com

Attn To: _____

Date: _____

EndMill

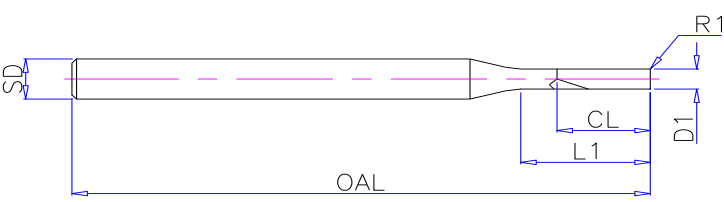

Taper EndMill

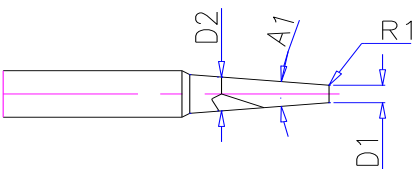

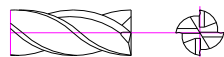

D1 ^{TOI.} _____ D2 ^{TOI.} _____
 CL _____ L1 _____
 A1 _____ R1 _____
 OAL _____ SD _____

Type

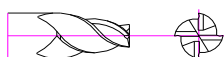
End Mill 

Taper E/M 

Corner Rad 

Ball Nose 

Flute Type Spiral (STD 30°) Straight (Other _____)

No. of Flute 2 3 4 6 8

Machining R/H Cut L/H Cut
 Plunging Side Cut

Coating: Tin Tialn DLC

WORK PIECE: Pls sketch below or Fax the Dwg.

Size & Tol. _____ Straightness _____
 Cut Length _____ Surface Finish _____

Mat. to Cut _____ **HRC** _____

Bore Type Blind Hole Through Hole

* What Tools are used for pre-operation before to this custom tool? eg: Pre Drill, Pre Mill
 Specify the Size _____

Other Info

*** Indicate Previous problems if any:**

*** Qty Required :**

*** Tool required Date:**

*** Tool Ref(if any)**

Enquiry From:

Contact Name: H/P:

Company Name Tel:

Address: Fax:

..... Email:

STAMFORD PRECISION TOOLS PTE LTD., SINGAPORE.